



Tractor Overturn Hazards

Dennis J. Murphy, Professor of Agricultural Engineering

No other farm machine is so identified with the hazards of production agriculture as the tractor. The rubber-wheeled, row-crop tricycle tractor of the 1930s revolutionized production agriculture. The tractor had the speed, power, flexibility, adaptability, and handling ease that helped move farming from the horse power era into the machine power era. The later additions of hydraulics, the three-point hitch, direct engine-driven power take-off (PTO), and variable shift transmissions firmly established the tractor as the primary machine in modern farming.

Center of Gravity

The central concept in tractor stability/instability is Center of Gravity (CG). A tractor's CG is the point where all parts balance one another. For example, when a two-wheel drive tractor is sitting with all wheels on level ground, the CG is typically about 10 inches (25.4 cm) above and two feet (0.6 m) in front of the rear axle, and in the center of the tractor body. This results in approximately 30 percent of the tractor weight on the front axle, and 70 percent on the rear axle. For four-wheel drive and center-articulated tractors, the CG is located slightly more forward. Added weights also effect the CG.

For a tractor to stay upright, its CG must stay within the tractor's stability baseline. Stability baselines are imaginary lines drawn between points where tractor tires contact the ground. The line connecting the rear tire contact points is the rear stability baseline, while the lines connecting the rear and front tires on the same side are the side stability baselines. Front stability baselines exist but have limited use in stability/instability considerations, and are not normally included in such discussions. See Figure 1 for a complete illustration of a tractor's CG and stability baselines.

While a tractor's CG does not move, its relationship with stability baselines may change. This most often

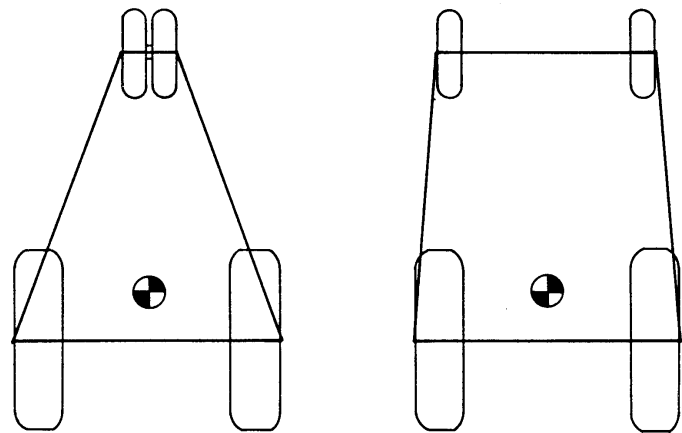

Figure 1. The stability baselines of a tricycle and a wide front-end tractor, respectively.

occurs as the tractor moves from a level position onto a slope. A changing CG-stability baseline relationship means the tractor is moving toward an unstable position. If the CG-stability baseline relationship changes significantly (e.g. tractor CG vector moves beyond the stability baseline), the tractor rolls over. Tractor CG action is no different from the CG action on any other mobile vehicle. What differs is that tractors have a higher CG when compared to most other vehicles, such as automobiles and trucks. The higher CG on modern tractors is an inherent design characteristic and relates to their operation over crops, residue, and rough terrain. Changing tractor design so that their CG is significantly lowered would largely defeat the purpose for having farm tractors.

When a tractor is on an incline, the distance between the tractor's CG and stability baseline is reduced. If equipment, such as a front-end loader, a round bale lifting fork, or a chemical side saddle tank is mounted on the tractor, the additional weight shifts the CG toward that piece of equipment. As mounted equipment is raised, the CG is raised. As Figure 2 illustrates, a higher CG decreases tractor stability. In many normal working situations, ground terrain and

mounted equipment combine to reduce the distance between the equipment's CG and stability baselines.

Other factors important to tractor stability/instability include centrifugal force (CF), rear-axle torque (RAT), and drawbar leverage (DBL). Each of these factors works through the CG. Saying this another way, each of these factors may cause the tractor's CG to go beyond the tractor's stability baseline and overturn.

Centrifugal Force

Centrifugal force is the outward force nature exerts on objects moving in a circular fashion. Within the context of tractor stability/instability, CF is that force trying to roll the tractor over whenever the tractor is turning. Centrifugal force increases both as the turning angle of the tractor becomes sharper (decreases), and as the speed of the tractor increases during a turn. The CF increase is directly proportional to the turning angle of the tractor. For every degree the tractor is turned tighter, there is an equal amount of increased CF.

The relationship between CF and tractor speed, however, is not directly proportional. Centrifugal force varies in proportion to the square of the tractor's speed. For example, doubling tractor speed from 3 mph to 6 mph increases the strength of centrifugal force four times ($2^2 = 2 \times 2 = 4$). Tripling tractor speed from 3 mph to 9 mph increases CF nine times ($3^2 = 3 \times 3 = 9$).

Centrifugal force is often a factor in tractor side overturns. When the distance between the tractor's CG and side stability baseline is already reduced from being on a hillside, only a little CF force may be needed to push the tractor over. Centrifugal force is what usually pushes a tractor over when the tractor is driven too fast during a turn, or during road travel. During road travel rough roads may

result in the tractor's front tires bouncing and landing in a turned position. Over correcting steering if the tractor starts to veer off the road is another example where CF is a factor in side overturns. The location of CG and amount of CF are points of stability/instability information tractor operators do not have at their disposal.

Rear-Axle Torque

Rear-axle torque involves energy transfer between the tractor engine and the rear axle of two-wheel drive tractors. Engaging the clutch of such tractors results in a twisting force, called torque, to the rear axle. This torque is then transferred to the tractor tires. Under normal circumstances the rear axle (and tires) should rotate and the tractor will move ahead. In lay terms, the rear axle is said to be rotating about the tractor chassis. If the rear axle should be unable to rotate, the tractor chassis rotates about the axle. This reverse rotation results in the front-end of the tractor lifting off the ground until the tractor's CG passes the rear stability baseline. At this point the tractor will continue rearward from its own weight until it crashes into the ground or other obstacle. The most common examples of this happening are when the rear tractor tires are frozen to the ground, are stuck in a mud hole, or are blocked from rotating by the operator.

A tractor may overturn from rear axle torque before an operator realizes that the overturn is imminent. Remember that the CG of a tractor is found closer to the rear axle than the front axle. Because of this, a tractor may only have to rear to about 75 degrees from a level surface before its CG passes the rear stability baseline and continues on over. This position is commonly called the "point of no return" (see Fig. 3). Research has shown that a tractor may reach this position in 3/4 of a second, and that it may take an operator longer than this to successfully stop the rearward

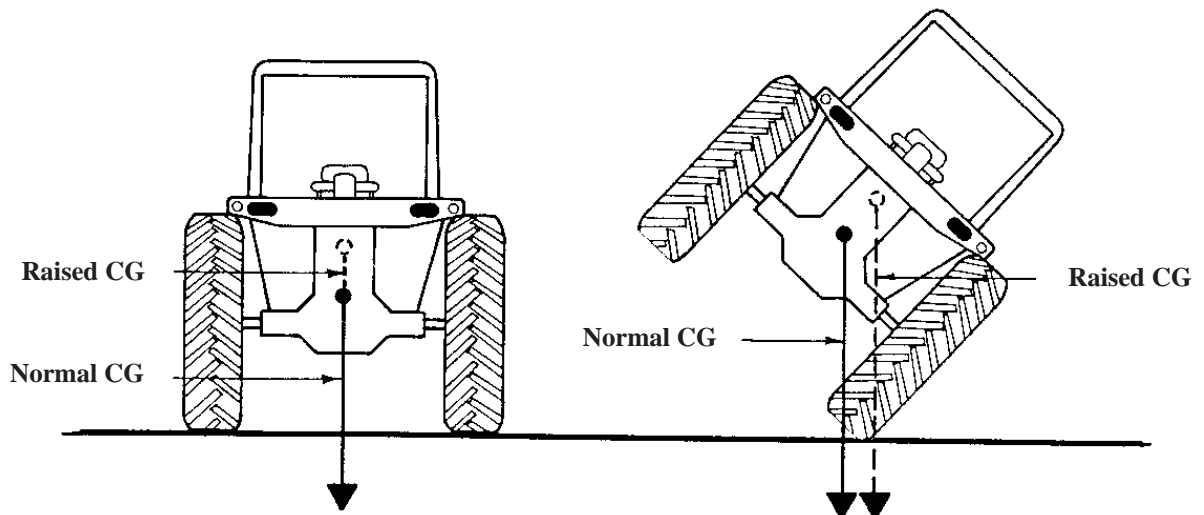

Figure 2. A higher CG allows a side overturn to occur more quickly.

motion. There are many tractor operating situations where there is even less than 3/4 of a second to recognize and successfully react to an impending rear overturn. For example, when a tractor is in a deep hole, or is traveling up a steep incline, the distance between the tractor's CG and rear stability baseline is narrowed. If excessive rear axle torque is applied, the tractor will reach the "point of no return" more quickly. Figure 4 illustrates this situation.

Four-wheel drive tractors are less susceptible to the rear axle torque hazard than two-wheel drive tractors because torque is applied to both the front and rear axles and tires. Also, more weight is carried on the front axle, moving the CG forward. These features lessen the tendency of the front of

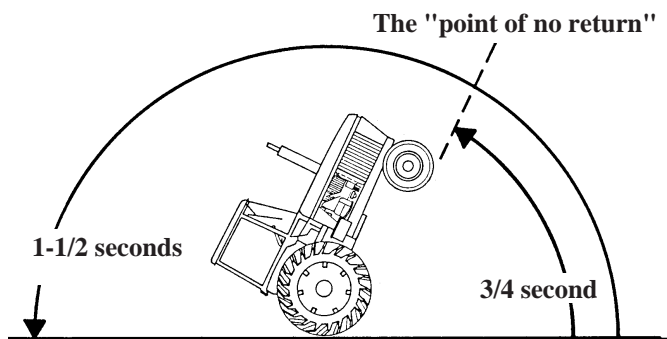

Figure 3. The "point of no return" during a rear turnover may be reached in 3/4 of a second.

(Source: Agricultural Safety, Deere and Company, Inc.)

four-wheeled drive tractors to lift off the ground. But, once the front end does lift, there is little practical difference between two- and four-wheeled drive tractors.

Drawbar leverage

Drawbar leverage is another principle of stability/instability related to rear overturns. When a two-wheel drive tractor is pulling a load, its rear tires push against the ground. Simultaneously, the load attached to the tractor is pulling back and down against the forward movement of the tractor. The load is said to be pulling down because the load is resting on the earth's surface. This backward and downward pull results in the rear tires becoming a pivot point, with the load acting as a force trying to tip the tractor rearward. An "angle of pull" is created between the ground's surface and the point of attachment on the tractor. Figure 5 illustrates these points. The heavier the load, and the higher the "angle of pull," the more leverage the load has to tip the tractor rearward.

A tractor, including its drawbar, is designed to safely counteract the rearward tipping action of pulled loads. When loads are attached to a tractor at any point other than its designed location, the design of the tractor for pulling loads is defeated. A tractor pulling a tree stump can be used

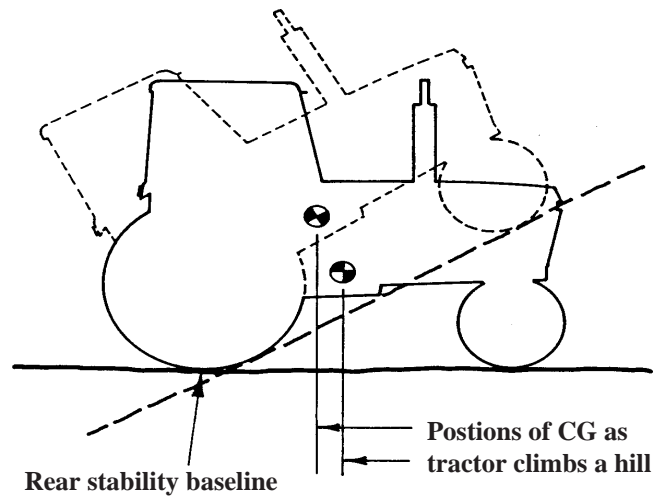

Figure 4. the CG moves toward the tractor's rear stability baseline when the tractor is headed up a hill, or if rear wheels are below normal ground surface, such as when stuck in soft ground.

as an example to show the effects of safe and unsafe hitching. Assumptions for this example include a tree stump that does not budge, a log chain that does not break, and a tractor with properly ballasted (weighted) tires and an engine that does not stall.

Suppose the tractor is hitched safely, that is, the log chain wrapped around the tree stump is attached to the tractor drawbar. The tractor is engaged and begins to pull on the stump. When the tree stump does not pull loose, the tractor will react in one of two ways. The most expected reaction will be a slipping (spinning) of the rear tires. This will continue until the operator stops the tractor. The second reaction may also involve a slipping of the rear tires, but the slipping may be neither smooth nor consistent. That is, they may slip with a jerking motion, and one tire may slip more than the other. Either one of these conditions may lead to a lifting of the front end of the tractor.

When the front end of the tractor lifts, the rear drawbar of the tractor will lower. This is a function of tractor geometry. The higher the front end raises, the lower the rear drawbar is driven. As the drawbar lowers, the "angle of pull" and the leverage the load has to tip a tractor rearward is also lowered. By design, a load will always lose its ability to tip a tractor rearward before the tractor's CG reaches the rear stability baseline. As the load loses its ability to continue to tip the tractor rearward, the front end falls back to the ground. If the tractor operator doesn't stop the pulling action, the entire process will repeat itself, resulting in a bouncing of the tractor's front end.

On the other hand, hitching unsafely, for example to a point higher than the drawbar, increases the "angle of pull" and leverage of a load. As the tractor tips rearward, these might not reduce to a harmless level before the tractor's CG reaches the rear stability baseline. When a load is hitched to

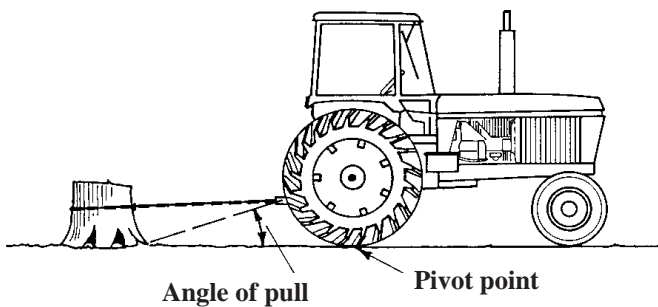

Figure 5. The "angle of pull" is rearward and downward. The point at which the rear tires contact the ground becomes the pivot point.

a rear axle, the "angle of pull" and leverage do not reduce as the front end raises because the location of the hitch point (rear axle) stays constant throughout the rearward tip. A higher hitch point also increases the pressure of the rear tires against the ground. This may prevent the rear tires from slipping. When the rear tires stop slipping, rear axle torque will begin lifting the front end. Accident reports suggest that most cases of improper hitching are associated with pulling and dragging nonmobile objects such as tree stumps, logs, fence posts, boulders, nonwheeled equipment such as large livestock feeders and tanks, and farm equipment mired in mud. The tractor operator is often tempted to hitch above the drawbar to lift the load while pulling it. Figures 6 and 7 illustrate safe and unsafe hitching.

Tractors trying to pull a load up an incline take less leverage to flip rearward because the tractor's CG is closer to the rear stability baseline. It is also possible to flip a tractor rearward when the load is properly hitched to the drawbar. This may happen when several factors occur. If the tractor is headed up an incline at too fast a speed and the load, such as a large log, suddenly digs into the ground, the rearward pull may be so quick and strong that the momentum generated by the rearward lift may result in a rear overturn.

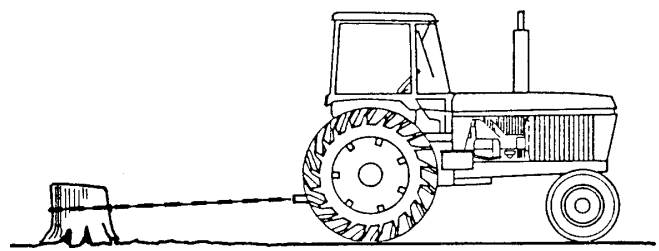

Figure 6. An example of safe hitching. The drawbar will lower if the front end rises. This reduces the "angle of pull" and the risk of a rear overturn.

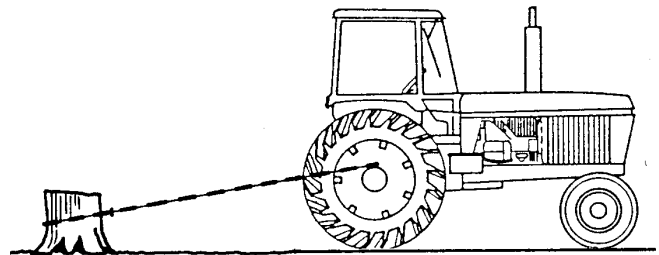

Figure 7. An example of unsafe hitching. The "angle of pull" does not lower if the front end rises, increasing the risk of a rear overturn.

Roll-Over Protective Structure and Seat Belt

The roll-over protective structure (ROPS) and seat belt, when worn, are the two most important safety devices to protect operators from death during tractor overturns. It is important to remember that the ROPS does not prevent tractor overturns. Rather, it prevents the operator from being crushed during an overturn. To work as designed, the operator must stay within the protective frame of the ROPS. This means the operator must wear the seat belt. Not wearing the seat belt may defeat the primary purpose of the ROPS.

A ROPS often limits the degree of rollover, which may reduce the probability of injury to the operator. A ROPS with enclosed cab further reduces the likelihood of serious injury because the operator is protected by the sides and windows of the cab. This assumes that cab doors and windows are not removed.

The Pennsylvania State University is committed to the policy that all persons shall have equal access to programs, facilities, admission, and employment without regard to personal characteristics not related to ability, performance, or qualifications as determined by University policy or by state or federal authorities. It is the policy of the University to maintain an academic and work environment free of discrimination, including harassment. The Pennsylvania State University prohibits discrimination and harassment against any person because of age, ancestry color, disability or handicap, national origin, race, religious creed, sex, sexual orientation, or veteran status. Discrimination or harassment against faculty, staff, or students will not be tolerated at The Pennsylvania State University. Direct all inquiries regarding the nondiscrimination policy to the Affirmative Action Director, The Pennsylvania State University, 201 Willard Building, University Park, PA 16802-2801, Tel 814-865-4700/V, 814-863-1150/TTY.